

INSTRUCTION MANUAL

Pizza Ovens

Item	40635	40636	45199
Model	PE-IT-0019-S	PE-IT-0038-D	PE-IT-0038-DS

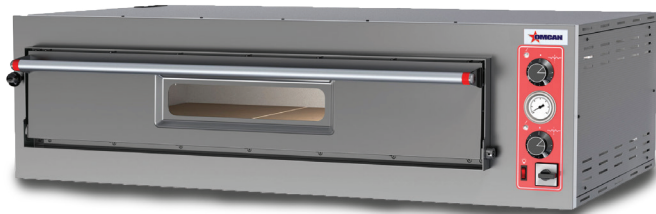

Warning!

Before you begin using your appliance, **PLEASE READ AND UNDERSTAND THIS DOCUMENT CAREFULLY** before installing, operating, maintaining, or servicing.

There are many important safety messages in this manual and on your appliance. Always read all safety messages.

Failure to do so can result in appliance failure, property damage, serious injury or death. Appliance failure, injury or property damage due to improper installation is not covered by warranty.

Stop!

DO NOT RETURN THIS PRODUCT TO THE STORE!

For questions or assistance with this product, call TRENTO Toll free: **1-833-487-3686** or visit the support section from our website, **www.trentoequipment.com**

Version: Revised - 05/09/2024



TABLE OF CONTENTS

Section	Page
General Information -----	3 - 4
Safety and Warranty -----	4 - 6
Technical Specifications -----	6
Installation -----	7 - 8
Operation -----	8 - 9
Maintenance -----	9 - 10
Troubleshooting -----	10
Parts Breakdown -----	11 - 15
Electrical Schematics -----	16 - 18
Warranty Registration -----	19

GENERAL INFORMATION

Omcan Manufacturing and Distributing Company Inc., Food Machinery of America, Inc. dba Omcan and Omcan Inc. are not responsible for any harm or injury caused due to any person's improper or negligent use of this equipment. The product shall only be operated by someone over the age of 18, of sound mind, and not under the influence of any drugs or alcohol, who has been trained in the correct operation of this machine, and is wearing authorized, proper safety clothing. Any modification to the machine voids any warranty, and may cause harm to individuals using the machine or in the vicinity of the machine while in operation.

CHECK PACKAGE UPON ARRIVAL

Upon receipt of an Omcan shipment please inspect for external damage. If no damage is evident on the external packaging, open carton to ensure all ordered items are within the box, and there is no concealed damage to the machine. If the package has suffered rough handling, bumps or damage (visible or concealed), please note it on the bill of lading before accepting the delivery and contact Omcan within 24 hours, so we may initiate a claim with the carrier. A detailed report on the extent of the damage caused to the machine must be filled out within three days, from the delivery date shown in the shipping documents. Omcan has no recourse for damaged products that were shipped collect or third party.

Before operating any equipment, always read and familiarize yourself with all operation and safety instructions.

Omcan would like to thank you for purchasing this machine. It's of the utmost importance to save these instructions for future reference. Also save the original box and packaging for shipping the equipment if servicing or returning of the machine is required.

Omcan Fabrication et distribution Compañie Limité et Food Machinery d'Amérique, dba Omcan et Omcan Inc. ne sont pas responsables de tout dommage ou blessure causé du fait que toute personne ait utilisé cet équipement de façon irrégulière. Le produit ne doit être exploité que par quelqu'un de plus de 18 ans, saine d'esprit, et pas sous l'influence d'une drogue ou d'alcool, qui a été formé pour utiliser cette machine correctement, et est vêtu de vêtements de sécurité approprié. Toute modification de la machine annule toute garantie, et peut causer un préjudice à des personnes utilisant la machine ou des personnes à proximité de la machine pendant son fonctionnement.

VÉRIFIEZ LE COLIS DÈS RÉCEPTION

Dès réception d'une expédition d'Omcan veuillez inspecter pour dommages externes. Si aucun dommage n'est visible sur l'emballage externe, ouvrez le carton afin de s'assurer que tous les éléments commandés sont dans la boîte, et il n'y a aucun dommage dissimulé à la machine. Si le colis n'a subi aucune mauvaises manipulations, de bosses ou de dommages (visible ou cachée), notez-le sur le bond de livraison avant d'accepter la livraison et contactez Omcan dans les 24 heures qui suivent, pour que nous puissions engager une réclamation auprès du transporteur. Un rapport détaillé sur l'étendue des dommages causés à la machine doit être rempli dans un délai de trois jours, à compter de la date de livraison indiquée dans les documents d'expédition. Omcan n'a aucun droit de recours pour les produits endommagés qui ont été expédiées ou cueilli par un tiers transporteur.

Avant d'utiliser n'importe quel équipement, toujours lire et vous familiariser avec toutes les opérations et les

GENERAL INFORMATION

consignes de sécurité.

Omcan voudrais vous remercier d'avoir choisi cette machine. Il est primordial de conserver ces instructions pour une référence ultérieure. Également conservez la boîte originale et l'emballage pour l'expédition de l'équipement si l'entretien ou le retour de la machine est nécessaire.

Omcan Empresa De Fabricacion Y Distribucion Inc. Y Maquinaria De Alimentos De America, Inc. dba Omcan y Omcan Inc. no son responsables de ningun daño o perjuicio causado por cualquier persona inadecuada o el uso descuidado de este equipo. El producto solo podra ser operado por una persona mayor de 18 años, en su sano juicio y no bajo alguna influencia de droga o alcohol, y que este ha sido entrenado en el correcto funcionamiento de esta máquina, y ésta usando ropa apropiada y autorizada. Cualquier modificación a la máquina anula la garantía y puede causar daños a las personas usando la máquina mientras esta en el funcionamiento.

REVISE EL PAQUETE A SU LLEGADA

Tras la recepcion de un envio Omcan favor inspeccionar daños externos. Si no hay daños evidentes en el empaque exterior, Habra el carton para asegurarse que todos los articulos solicitados estén dentro de la caja y no encuentre daños ocultos en la máquina. Si el paquete ha sufrido un manejo de poco cuidado, golpes o daños (visible o oculto) por favor anote en la factura antes de aceptar la entrega y contacte Omcan dentro de las 24 horas, de modo que podamos iniciar una reclamación con la compañía. Un informe detallado sobre los daños causados a la máquina debe ser llenado en el plazo de tres días, desde la fecha de entrega que se muestra en los documentos de envío. Omcan no tiene ningun recurso por productos dañados que se enviaron a recoger por terceros.

Antes de utilizar cualquier equipo, siempre lea y familiarizarse con todas las instrucciones de funcionamiento y seguridad.

Omcan le gustaría darle las gracias por la compra de esta máquina. Es de la mayor importancia para salvar estas instrucciones para futuras consultas. Además, guarda la caja original y el embalaje para el envío del equipo si servicio técnico o devolución de la máquina que se requiere.

SAFETY AND WARRANTY

WARNINGS FOR THE INSTALLER

Check that the location of the oven is in compliance with local regulations.

- Adhere to the instructions in this manual.
- Do not execute electrical connections using temporary or uninsulated cables.
- Check that the ground connection of the electrical system is functioning properly.
- Always use individual safety devices and other means of protection in compliance with the law.

Note: installing a hood for ventilation is not required with adequate ventilation in the kitchen.

SAFETY AND WARRANTY

WARNING FOR THE USER

The conditions in the surrounding area where the machine will be installed must have the following characteristics:

- The area must be dry.
- The area must have water and heat sources at an adequate distance.
- Ventilation and lighting must be suitable and comply with the hygiene and safety standards foreseen by current laws.
- The floor must be flat and compact to facilitate thorough cleaning.
- There must be no obstacles of any kind in the immediate vicinity of the machine that could effect the machine's normal ventilation.

In addition, the user must:

- Make certain to keep children away from the machine when it is operating.
- Adhere to the instructions in this manual.
- Not remove or tamper with the safety devices on the machine.
- Always pay careful attention to the work at hand and not use the machine when in a distracted state.
- Perform all operations with maximum safety and calm.
- Respect the instructions and warnings displayed on the machine labels.

The labels are accident prevention devices, and therefore must always be perfectly legible. If these should be damaged and illegible, it is mandatory to replace them by requesting replacements from the manufacturer.

- At the end of each working shift, before cleaning, maintenance or transfer operations, disconnect electrical power.

WARNINGS FOR THE MAINTENANCE OPERATOR

Observe the instructions indicated in this manual.

- Always use individual safety devices and other protection means.
- Before starting any maintenance operations, make sure that the oven, it was used, is cooled down.
- If any of the safety devices is worn or faulty, the oven is also considered faulty and not to be used.
- Disconnect electrical power before intervening on electrical or electronic parts and connectors.

RESIDENTIAL USERS: vendor assumes no liability for parts or labor coverage for component failure or other damages resulting from installation in non-commercial or residential applications. The right is reserved to deny shipment for residential usage; if this occurs, you will be notified as soon as possible.

1 YEAR PARTS AND LABOUR WARRANTY

Within the warranty period, contact Trento Inc. at 1-800-465-0234 to schedule a Trento authorized service technician to repair the equipment locally.

Unauthorized maintenance will void the warranty. Warranty covers electrical and part failures, not improper use.

SAFETY AND WARRANTY

Please see <https://omcan.com/disclaimer> for complete info.

WARNING:

The packaging components are classified as normal solid urban waste and can therefore be disposed of without difficulty.

In any case, for suitable recycling, we suggest disposing of the products separately (differentiated waste) according to the current norms.

DO NOT DISCARD ANY PACKAGING MATERIALS IN THE ENVIRONMENT!

TECHNICAL SPECIFICATIONS

Model	PE-IT-0019-S	PE-IT-0038-D	PE-IT-0038-DS
Item Number	40635	40636	45199
Electrical	220V / 60Hz / 3		220V / 60Hz / 1
Power	5.6 kW	11.2 kW	
Maximum Temperature	450°C / 842°F		
Number of Chambers	1	2	
Chamber Dimensions	27.6" x 27.6" x 5.9" / 700 x 700 x 150mm		
Full Refractory Stone Dimensions	26.4" x 27" x 5.3" / 670 x 685 x 135mm		
External Dimensions	39" x 36.2" x 15" 990 x 920 x 380mm	39" x 36.2" x 26.8" 990 x 920 x 680mm	
Packaging Dimensions	40.2" x 39" x 20.9" 1020 x 990 x 530mm	40.2" x 39" x 32.3" 1020 x 990 x 820mm	
Weight	163.1 lbs. / 74 kgs.	328.5 lbs. / 149 kgs.	
Packaging Weight	169.8 lbs. / 77 kgs.	363.8 lbs. / 165 kgs.	

**Bake time may vary depending on the toppings and dough consistency.*

***Based on 14" Pizza.*

INSTALLATION

OVEN INSTALLATION LOCATION

The minimum distances that must be respected when positioning the machine to facilitate use, cleaning and maintenance of the oven.

The minimum distance that must be respected between the oven and surrounding walls or other machines must be at least 9.8" / 25cm on the left and 19.7" / 50cm on the right and rear.

Installation must be executed by qualified personnel in compliance with local and national regulations.

OVEN POSITIONING

Ensure that the oven is put on a stand with the suitable carrying capacity and that it is flat. After unpacking the oven from its packing, position it in prepared location, taking into account the minimum distances. Remove possible protections in polystyrene and take off the protecting film (F) avoid use of tools which can damage the surfaces.

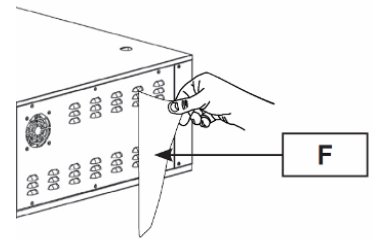

EQUIPMENT HOOK-UP

Electrical connection

The oven is not provided with power supply cable. When connecting the appliance electrically, an automatic RCD must be interposed with an opening distance between contacts of at least 3 mm. To connect the appliance electrically it is essential to proceed in the following way:

- Remove the right side panel.
- Connect to the terminal block the power cable.

The power supply cable must be of H07-RNF type, with approved minimum cross section as prescribed by the specific directive.

The electrical outlet must be easy to access, no moving should be necessary.

The electrical connection (plug) must be easily accessible, also following oven installation.

The distance between the machine and the socket must be adequate to not cause tension in the power supply cable. In addition, the cable must not be located beneath the machine support base.

If the electrical power supply cable is damaged, it must be replaced by the technical assistance service or by a qualified technician to prevent any risks.

INSTALLATION

GROUND CONNECTION

It is mandatory that the electrical system is equipped with a ground connection.

The appliance must be part of an equipotential system. The connection is done on terminal marked with symbol which you will find near the cable clamp. The section of the equipotential wire must be at least 10mm². The equipotential symbol is showed in the following figure.



OPERATION

COMMAND PANEL DESCRIPTION

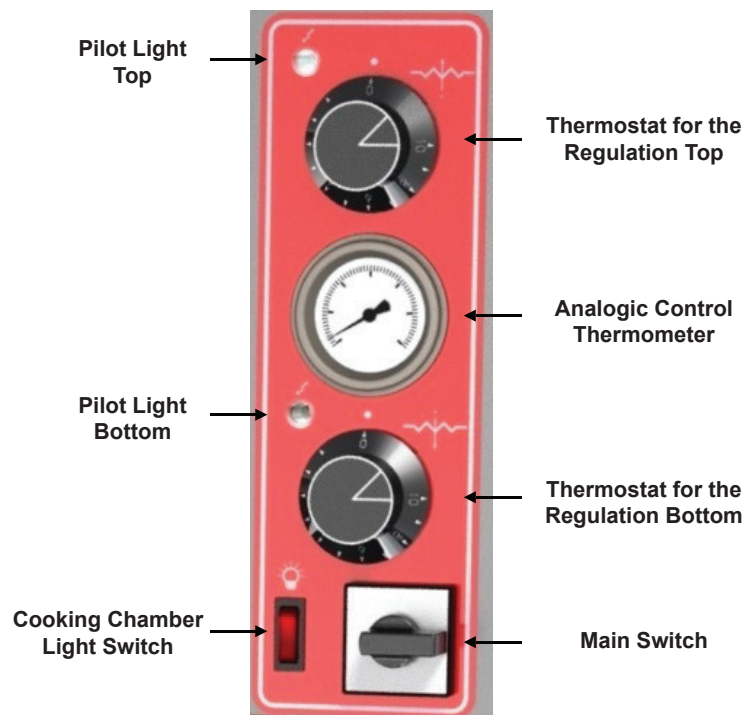

FIRST LIGHTING OF THE OVEN

At the first use of the appliance it is advisable to heat the empty oven to eliminate bad smells caused by the refractory stones evaporation and the inner metallic parts.

Procedure:

- Fully open the exhauster valve.
- Turn the main switch in position "1".

OPERATION

- Leave the oven working (empty) for at least 8 hours at the temperature of 300° before proceeding to the first baking.

START UP PHASE

The analogical thermometer display shows the actual average temperature of the baking chamber. Rotate the thermostat knobs and until the expected temperature. In this way top and bottom heating elements are under working and the relevant light signals switch on.

USE OF EXHAUSTER VALVE

While baking regulate the valve according to the exigencies. Oven is under heating; so, the set temperature is reached in shortest possible time. By the exhauster valve the operator can regulate the baking steams and fumes flow out from the baking chamber, while in the same the heat is kept.

SHUT DOWN PHASE

To shut down the oven turn the thermostat to the position "0".

MAINTENANCE

SAFETY PRECAUTIONS

Before performing any maintenance operations, including cleaning, take the following precautions:

- Ensure that the oven is not working and completely cold.
- Ensure that the electrical power is not present.
- Make certain that the electrical power cannot be accidentally reinserted. Disconnect the plug from the electrical power socket.
- Use individual protection devices in compliance with the directive 89/391/CEE.
- Always operate using appropriate maintenance tools.
- Once maintenance and repairs are finished, before starting up the oven, reinstall all of the protection devices and reactivate all of the safety devices.

ORDINARY MAINTENANCE FOR THE USER

As any equipment also our ovens requires simple, frequent and careful cleaning to ensure efficient, regular functioning. It is recommended to never use chemical products which are not specific for food preparation areas, abrasives or corrosives for any reason. Avoid by all means using water jets, tools, rough or abrasive instruments, such as steel wool, brillo sponges or any other item which could damage the surface of the machine, and especially those that could compromise health safety. Oven external areas cleaning, external parts in stainless steel, door glass, and switch panel, must be carried out at cold oven and at disconnected

MAINTENANCE

electric power supply. Use a sponge or a soft cloth, not abrasive, slightly humidified with water or possibly with a neutral detergent not corrosive. In any case, do not use water jets which can penetrate through the electric parts and heavily damage them, as well as bring a possible danger for people.

TROUBLESHOOTING

SYMPTOM	POSSIBLE CAUSE	SUGGESTED REMEDY
The oven does not heat even though the temperatures are set correctly. The pilot lights are off.	Main switch in position "0".	Turn the main switch in position "1".
The oven doesn't heat despite the main switch is on (position 1) and the temperatures are correctly set. The function pilot lights of the heating elements are off.	No electric energy in the net.	Check the general contactor, the socket, the plug, and the supply cable.
The analogical thermometer doesn't notice the increase of the temperature despite the heating elements are correctly functioning.	Analogical thermometer defect.	Check and if necessary replace the thermometer.
Inner light bulb does not switch on.	Burned inner light bulb.	Replace inner light bulb.
	Inner light bulb switch defected.	Replace light bulb switch.
	No electric supply power on the light bulb.	Check electric connection with the light bulb.
The door is closed, but fume comes out.	Exhauster butterfly valve closed.	Open more the valve and check the right functioning.
The baking chamber does not heat suitably.	The set temperature are too low.	Set the right temperature.
The baking chamber does not heat suitably in spite of the temperature being set rightly.	One or more heating elements are defected.	Replace the defecate heating elements.
The temperature continues going up over the set by thermostats.	Thermostat probe or thermostat contacts defected.	Check and if necessary replace the thermostats.
The door does not keep right closed.	The door closing spring has subsiding.	Disassemble the left side panel and replace the spring.

PARTS BREAKDOWN

ITEM	MODEL
40635	PE-IT-0019-S
40636	PE-IT-0038-D
45199	PE-IT-0038-DS

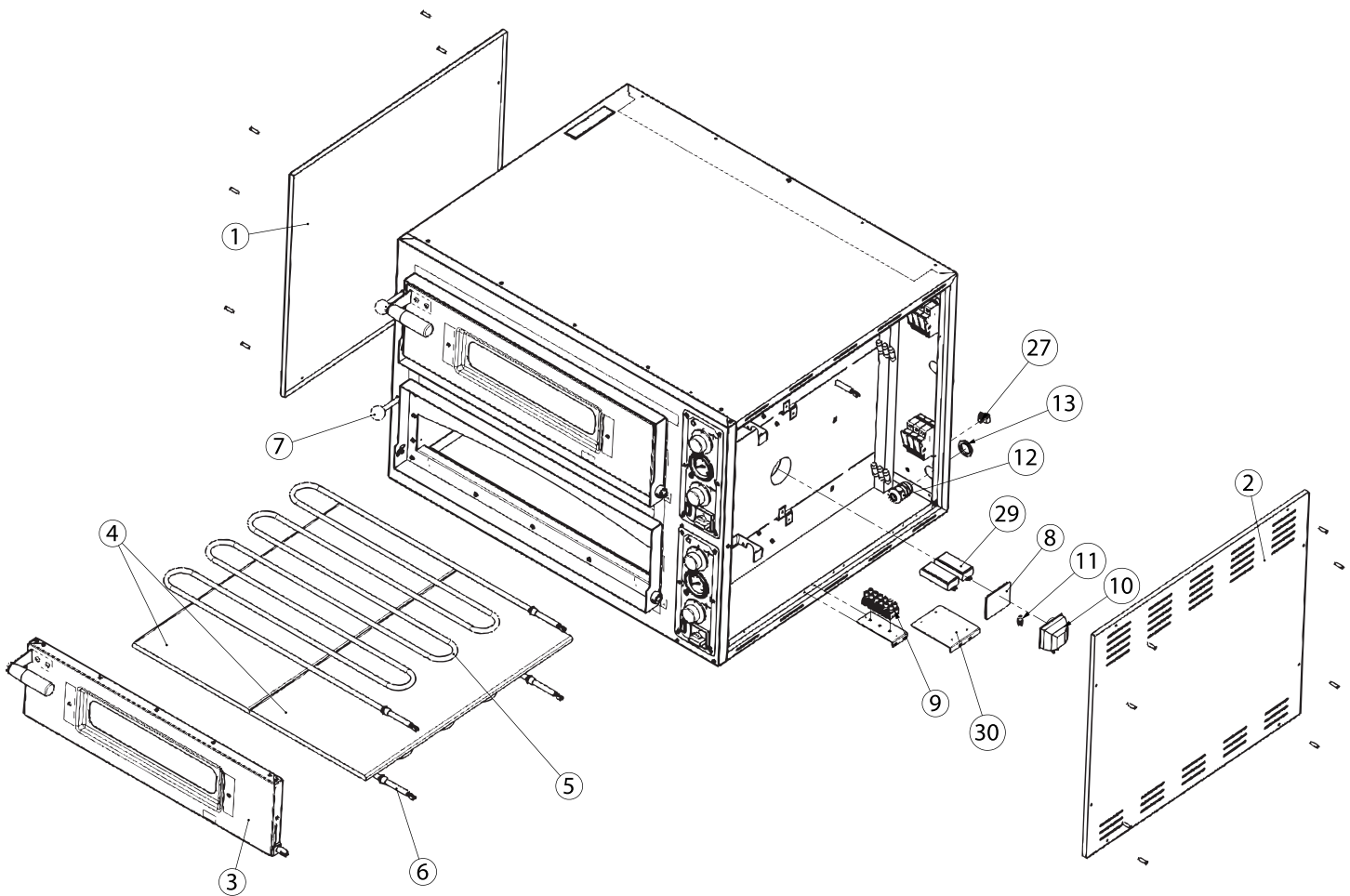

PARTS BREAKDOWN

ITEM	MODEL
40635	PE-IT-0019-S
40636	PE-IT-0038-D
45199	PE-IT-0038-DS

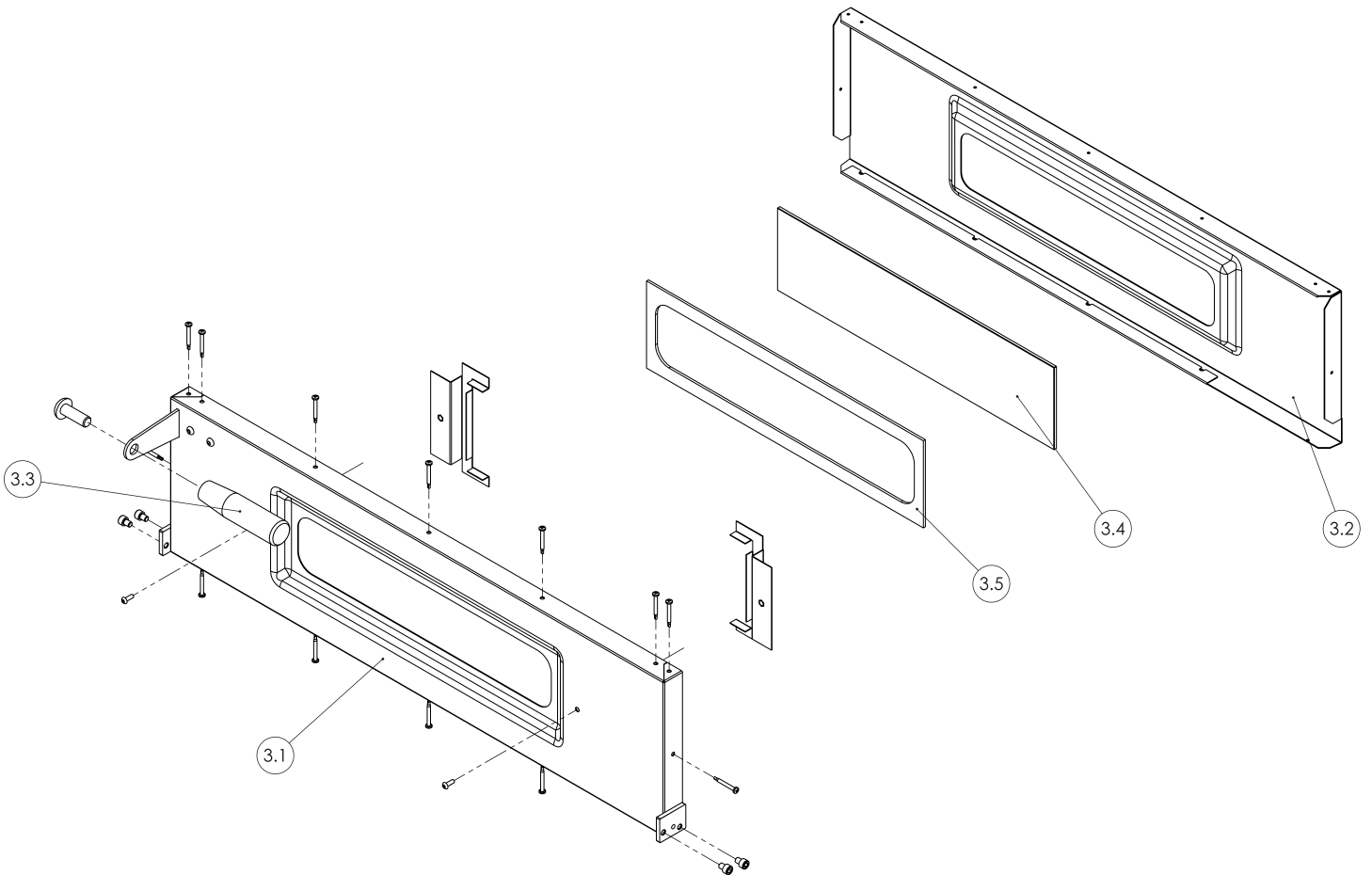

PARTS BREAKDOWN

ITEM	MODEL
40635	PE-IT-0019-S
40636	PE-IT-0038-D
45199	PE-IT-0038-DS

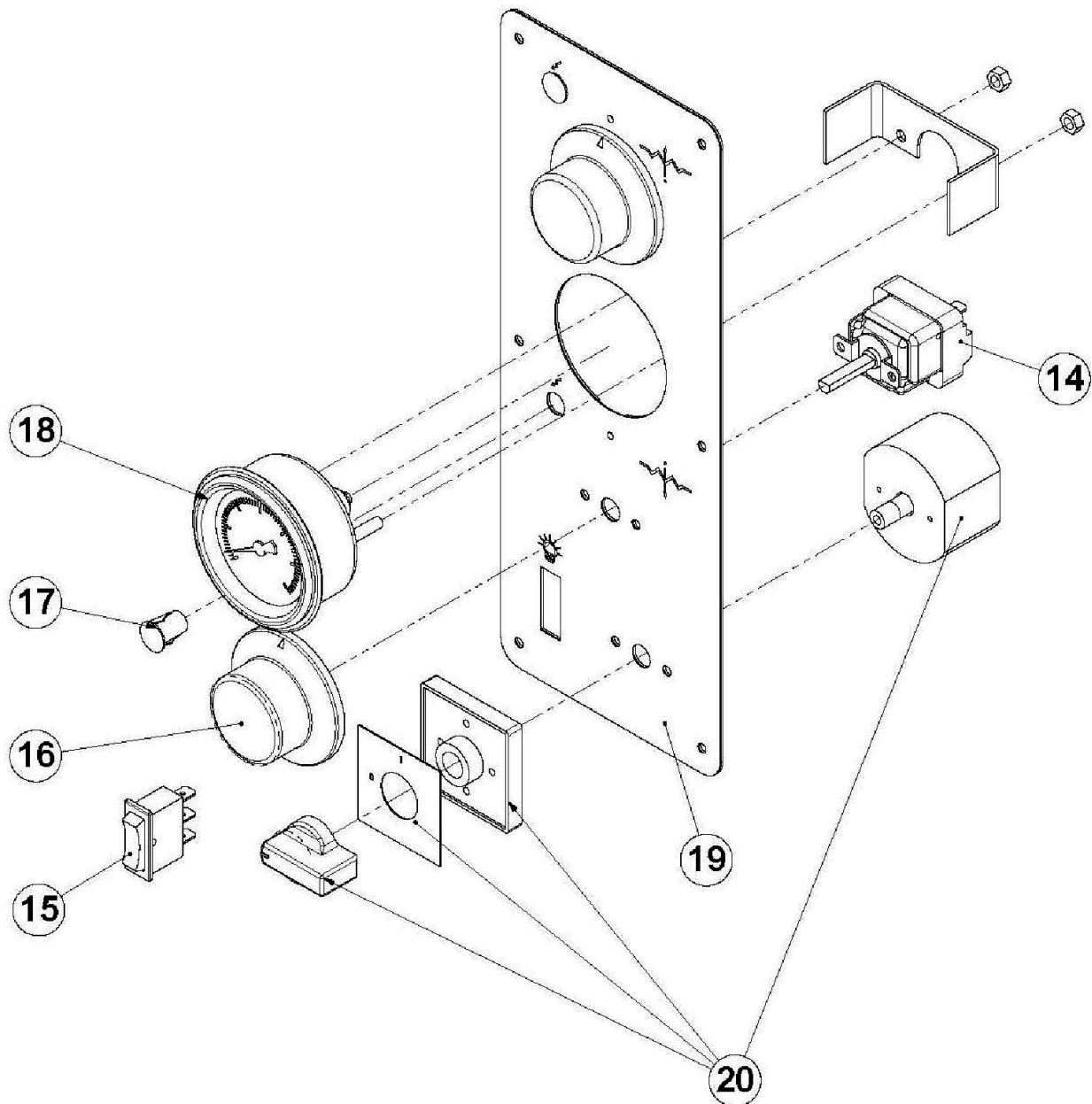

PARTS BREAKDOWN

ITEM	MODEL
40635	PE-IT-0019-S

Item No.	Description	Position	Item No.	Description	Position	Item No.	Description	Position
76602	Entry LH Side Panel for 40635	1	AC196	Rectangular Lamp Glass for 40635	8	76626	Entry Control Label for 40635	19
76603	Entry RH Side Panel for 40635	2	42831	Terminal Board PA220FV 12 Poles 16sqmm 750V-76A for 40635	9	42035	16A Acuator P0160004R001 4-Polar Switch for 40635	20
76604	Entry Complete Door for 40635	3	AC197	Lamp Holder with Bulb and Cover for 40635	10	74760	Grey Plate/Black Knob 48x48 for Giovenzana Mainswitch 16/32 A for 40635	20
76605	Entry Door Assembly for 40635	3.1	74855	Halogen Bulb 12V 20W G4 for 40635	11	42849	Resin Bonded Label for 40635	22
76606	Counter Door Assembly for 40635	3.2	74747	Cable Gland OBO 106 PG 21 for 40635	12	42837	Equipotential Attachment (OBO. T5012+OBO.5016M5) for 40635	27
76607	Elesa Handle I 280/115 for 40635	3.3	74746	Nut for Cable Gland OBO 106 PG 11 for 40635	13	62493	Transformer 40VA 50/60Hz 230V-12V for 40635	29, 30
41771	Glass Door for 40635	3.4	AM897	Unipolar Thermostat EGO 450 Deg - (55.19082.805 - EU) for 40635	14	AM699	Thermostat Probe Support Safety T.D. 8438.90.00 (Bracket) for 40635	
76609	Joint Entry for 40635	3.5	42048	Luminous Unipolar Red Switch for 40635	15	AM700	Unipolar Safety Thermostat 512TH - UL (55.13584.010) T.D. 8514.90.70 for 40635	
76650	Brick 350x700x14 for 40635	4	76646	Thermostat Knob AP Scale 0-10 for 40635	16	AM701	Vite TC+ Autofor. 3.9x13 ZN NR 24.00 N8E T.D. 7318.12.10 for 40635	
76612	Resistor 2800 W 230 V Prime for 40635	5, 6	42848	Transparent LED Bulb 380V (Including Hood) for 40635	17			
76614	Spheric Knob PLX.30-M8-C9 for 40635	7	74749	Thermometer Ø 60 TAR. 0-500C for 40635	18			

PARTS BREAKDOWN

ITEM	MODEL
40636	PE-IT-0038-D
45199	PE-IT-0038-DS

Item No.	Description	Position	Item No.	Description	Position	Item No.	Description	Position
77228	Entry LH Side Panel for 40636, 45199	1	AC196	Rectangular Lamp Glass for 40636, 45199	8	76626	Entry Control Label for 40636, 45199	19
77229	Entry RH Side Panel for 40636, 45199	2	42831	Terminal Board PA220FV 12 Poles 16sqmm 750V-76A for 40636, 45199	9	42035	16A Actuator P0160004R001 4-Polar Switch for 40636, 45199	20
76604	Entry Complete Door for 40636, 45199	3	AC197	Lamp Holder with Bulb and Cover for 40636, 45199	10	74760	Grey Plate/Black Knob 48x48 for Giovenzana Mainswitch 16/32 A for 40636, 45199	20
76605	Entry Door Assembly for 40636, 45199	3.1	74855	Halogen Bulb 12V 20W G4 for 40636, 45199	11	42849	Resin Bonded Label for 40636, 45199	22
76606	Counter Door Assembly for 40636, 45199	3.2	74747	Cable Gland OBO 106 PG 21 for 40636, 45199	12	42837	Equipotential Attachment (OBO. T5012+OBO.5016M5) for 40636, 45199	27
76607	Elesa Handle I 280/115 for 40636, 45199	3.3	74746	Nut for Cable Gland OBO 106 PG 11 for 40636, 45199	13	62493	Transformer 40VA 50/60Hz 230V-12V for 40636, 45199	29, 30
41771	Glass Door for 40636, 45199	3.4	AM897	Unipolar Thermostat EGO 450 Deg - (55.19082.805 - EU) for 40636, 45199	14	AM699	Thermostat Probe Support Safety T.D. 8438.90.00 (Bracket) for 40636, 45199	
76609	Joint Entry for 40636, 45199	3.5	42048	Luminous Unipolar Red Switch for 40636, 45199	15	AM700	Unipolar Safety Thermostat 512TH - UL (55.13584.010) T.D. 8514.90.70 for 40636, 45199	
76650	Brick 350x700x14 for 40636, 45199	4	76646	Thermostat Knob AP10 Scale 0-10 for 40636, 45199	16	AM701	Vite TC+ Autofor. 3.9x13 ZN NR 24.00 N8E T.D. 7318.12.10 for 40636, 45199	
76612	Resistor 2800 W 230 V Prime for 40636, 45199	5, 6	42848	Transparent LED Bulb 380V (Including Hood) for 40636, 45199	17			
76614	Spheric Knob PLX.30-M8-C9 for 40636, 45199	7	74749	Thermometer Ø 60 TAR. 0-500C for 40636, 45199	18			

ELECTRICAL SCHEMATICS

ITEM	MODEL
40635	PE-IT-0019-S

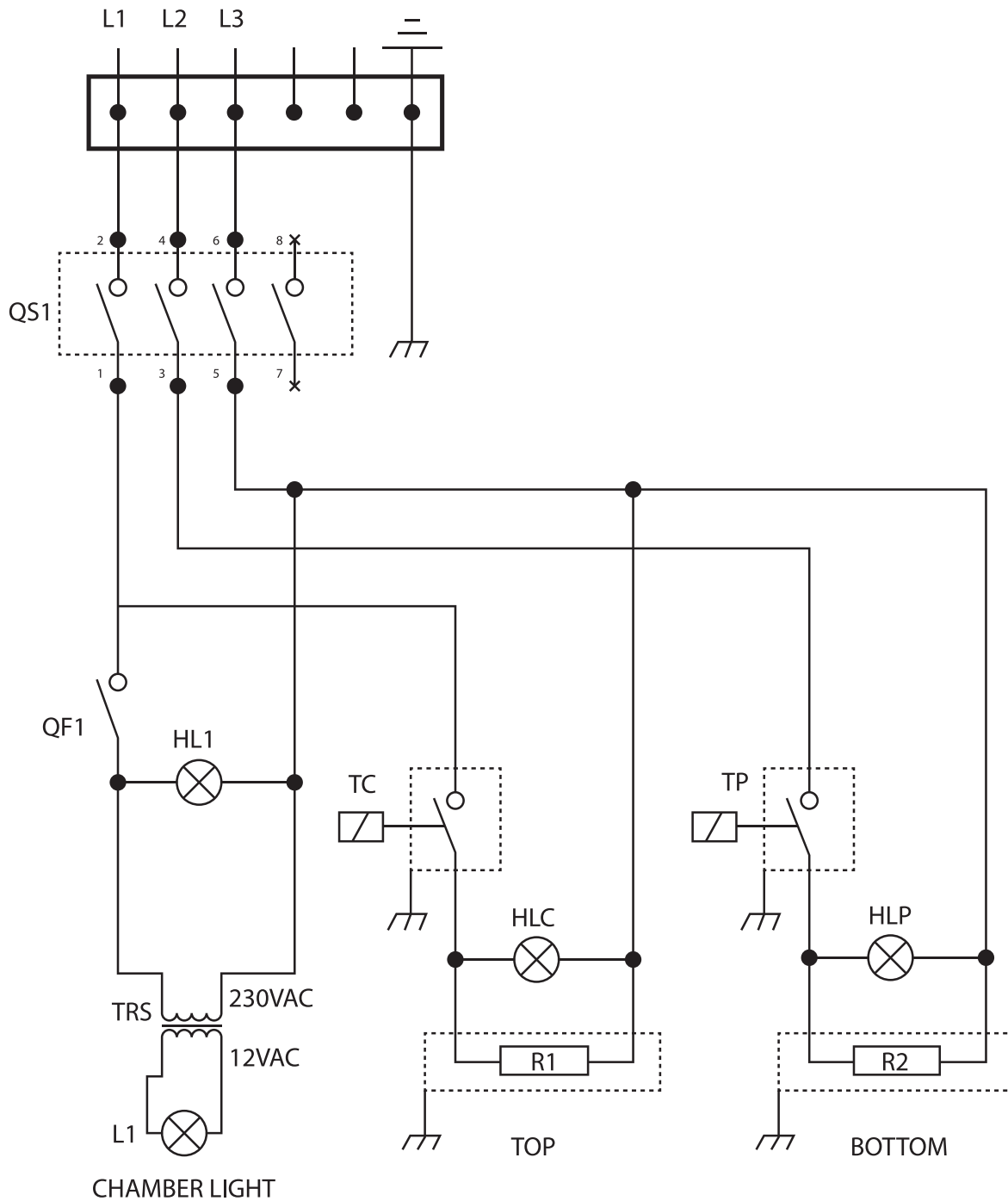

ELECTRICAL SCHEMATICS

ITEM	MODEL
40636	PE-IT-0038-D

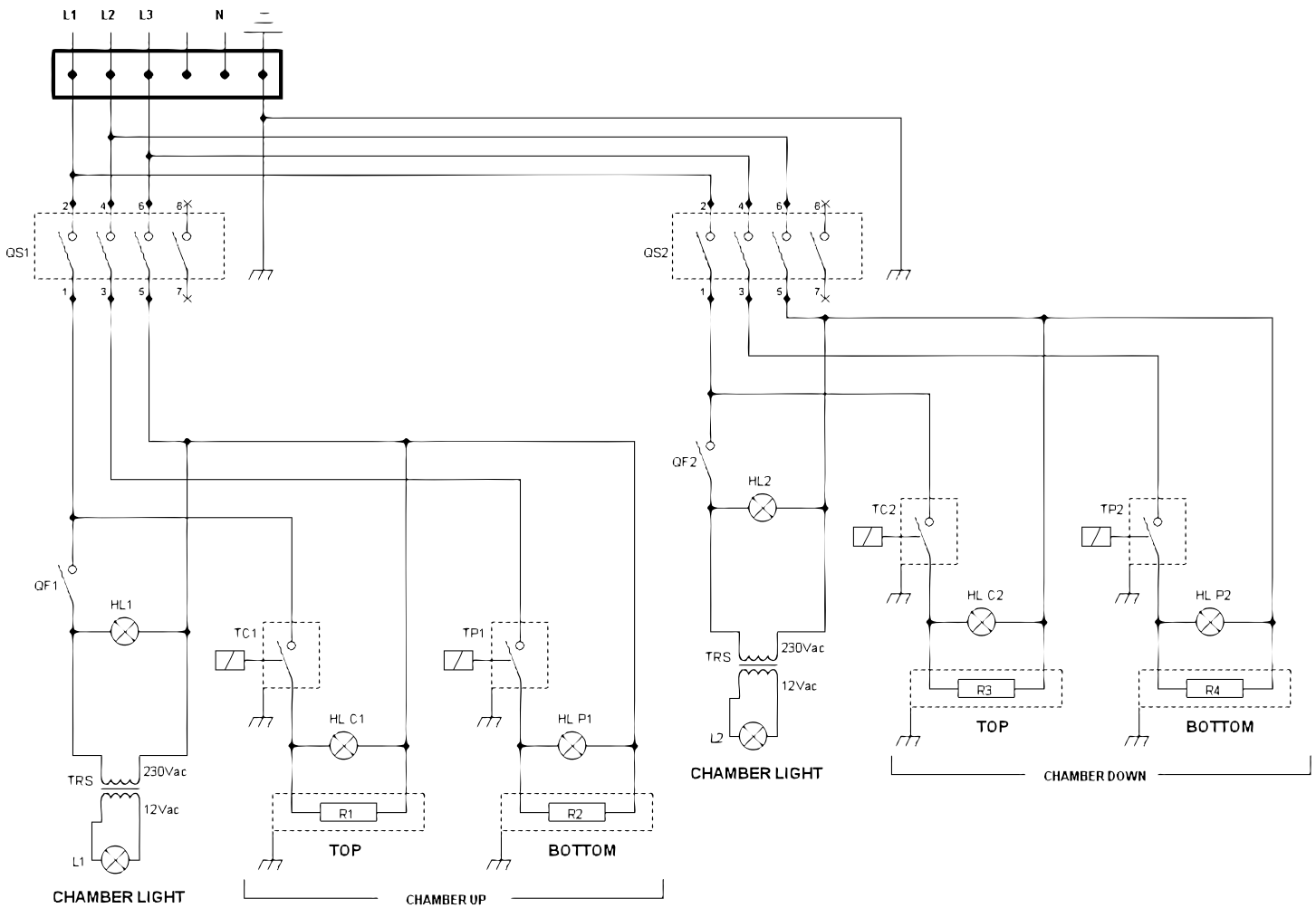

ELECTRICAL SCHEMATICS

ITEM	MODEL
45199	PE-IT-0038-DS

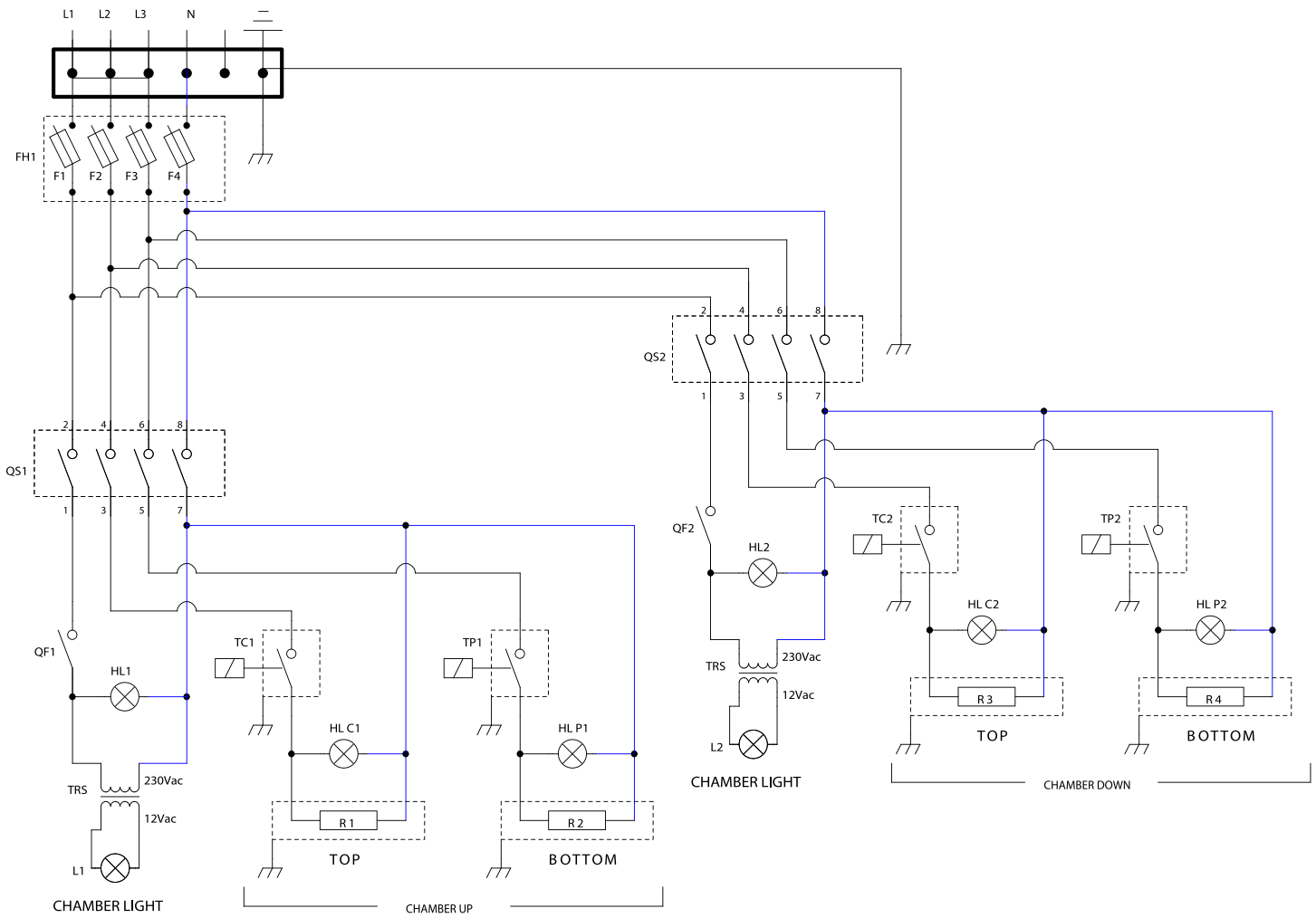

WARRANTY REGISTRATION

Thank you for purchasing an Trento product. To register your warranty for this product, complete the information below, tear off the card at the perforation and then send to the address specified below. You can also register online by visiting:

Merci d'avoir acheté un produit Trento. Pour enregistrer votre garantie pour ce produit, complétez les informations ci-dessous, détachez la carte au niveau de la perforation, puis l'envoyer à l'adresse spécifiée ci-dessous. Vous pouvez également vous inscrire en ligne en visitant:

Gracias por comprar un producto Trento usted. Para registrar su garantía para este producto, complete la información a continuación, cortar la tarjeta en la perforación y luego enviarlo a la dirección indicada a continuación. También puede registrarse en línea en:

<https://omcan.com/warranty-registration/>

For mailing in Canada

Pour postale au Canada

Por correo en Canadá

For mailing in the US

Pour diffusion aux États-Unis

Por correo en los EE.UU.

TRENTO

PRODUCT WARRANTY REGISTRATION

3115 Pepper Mill Court,
Mississauga, Ontario
Canada, L5L 4X5

TRENTO

PRODUCT WARRANTY REGISTRATION

4450 Witmer Industrial Estates, Unit 4,
Niagara Falls, New York
USA, 14305

or email to: trentoservice@trentoequipment.com



Purchaser's Information

Name: _____ Company Name: _____

Address: _____ Telephone: _____

City: _____ Province or State: _____ Postal or Zip: _____ Email Address: _____

Country: _____ Type of Company: _____

Dealer from which Purchased: _____ Restaurant Bakery Deli

Dealer City: _____ Dealer Province or State: _____ Butcher Supermarket Caterer

Invoice: _____ Institution (specify): _____

Model Name: _____ Model Number: _____ Serial Number: _____

Machine Description: _____

Date of Purchase (MM/DD/YYYY): _____ Date of Installation (MM/DD/YYYY): _____

Would you like to extend the warranty? Yes No

Thank you for choosing Trento | Merci d'avoir choisi Trento | Gracias por elegir Trento

TRENTO

ELEVATING CULINARY EXCELLENCE

TRENTO IS A SIGNATURE LINE OF PROFESSIONAL
RESTAURANT EQUIPMENT FROM OMCAN
OFFERING PREMIUM EUROPEAN BRANDS TO THE
NORTH AMERICAN MARKET.

Thank you for your purchase!



Follow us on social media
@trentoequipment

